

21 4x2 Pent Garden Tidy

Instruction Manual



21 Instruction Manual

The type and quantity of components may vary for different style sheds. Assembly of all shed styles is by the same method as detailed.

Before assembling the shed, please check that all parts are present. Report any shortages or other issues immediately.

No.	Components	Number
1	Front panel	1
2	Rear panel	1
3	Left side panel	1
4	Right side panel	1
5	Doors	2
6	Floor	1
7	Roof panel	1
8	Cover strips	4
9	Roof Trim (Barge Boards)	4
10	Roofing Felt	1
11	Tee Hinges	6
12	Turn button	2
13	Hasp and Staple	1

Adequate provision must be made to ensure that the floor boards of the building do not come into direct contact with the ground and air is able to circulate underneath. A concrete or paving slab base is acceptable, but the building must not be allowed to sit in pooled water during wet conditions.

Timber Information.

Timber is a natural product and can therefore be subject to warping, shrinkage, splitting, etc. Periods of excessive dry spells can cause the timber to lose internal moisture, resulting in shrinkage on a panel. During periods of excessive wet spells, the timber may experience some swelling. Unfortunately, this process cannot be avoided.

If you have problems with certain boards shrinking, try to decrease the amount of direct sunlight it gets. During hot spells, spray any shrunken boards with a hosepipe - this will replenish the moisture in the timber.

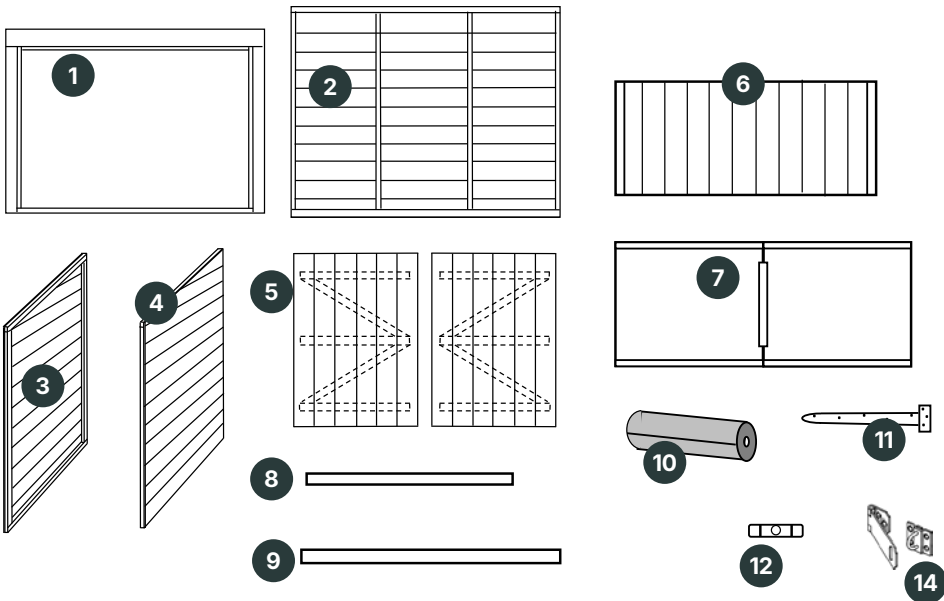

Fixings

60mm screws

32mm ringshank nails

40mm screws

13mm clout nails

25mm black screws

If you have any questions or queries during the assembly of your building please contact us:



Helpline: 01384 897257

Opening hours: Monday – Friday 9am – 4.30pm

We are constantly improving and updating the quality of our products and as such some components may differ from those shown. We reserve the right to change the specification of our products without prior notice.

1. Floor & Wall Panels

Step 1.

Position the first side panel (one of the panels with the sloping top) so that the edge of the panel is flush with the edge of the floor at both sides and the overhang on the bottom of the panel is butted up to the floor. These panels are the same width as the floor board.

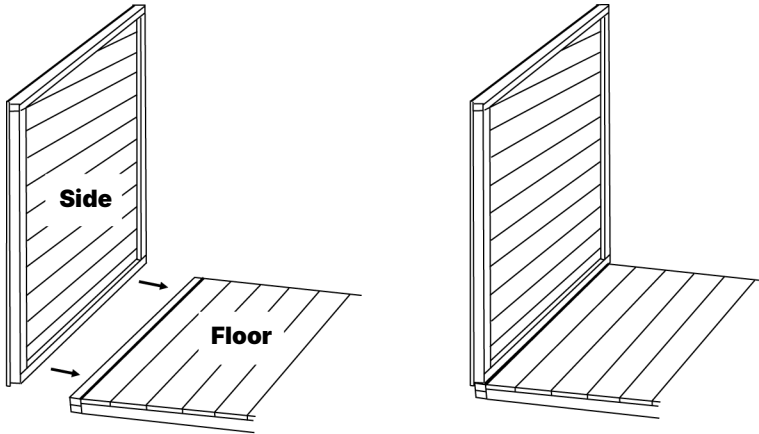

Step 2.

Position the rear panel next to the end panel to make a corner. The cladding of the front/rear panel should be proud of the end panel to allow fitting of the corner cover strips, as shown below.

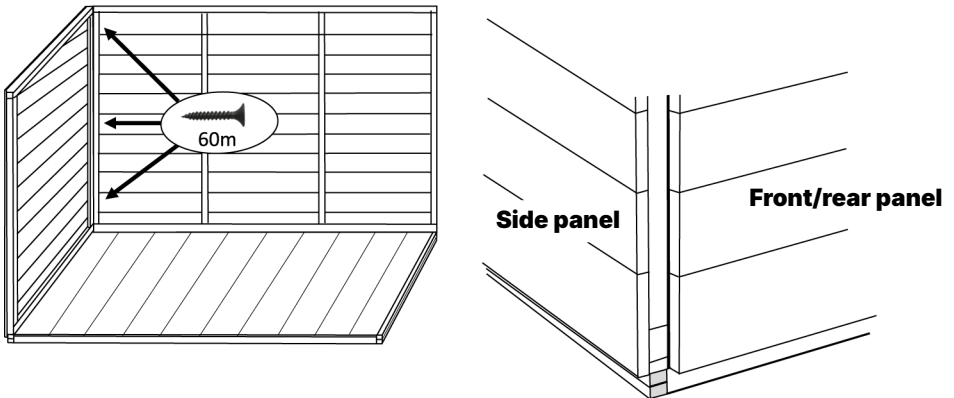

Step 3.

Fix the remaining panels in place using the method shown in step 2.

Do not screw any of the panels to the floor at this point.

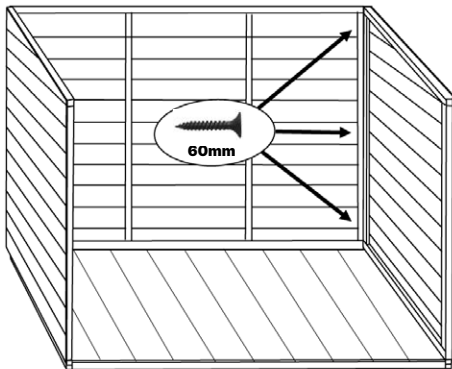
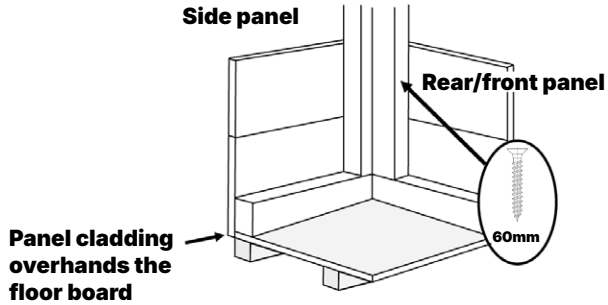

Once all walls are assembled, ensure the shed is now square on the floor. Using the 60mm screws, fix the walls panels to the floor. Do this by screwing through the framing of the wall panel, through the floor and into the floor bearer. Use 2 to 4 screws per wall panel.

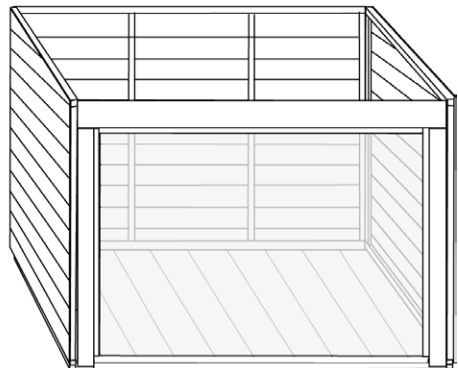

Step 4.

Attach the corner cover trim to all 4 corners as shown, using 32mm nails.

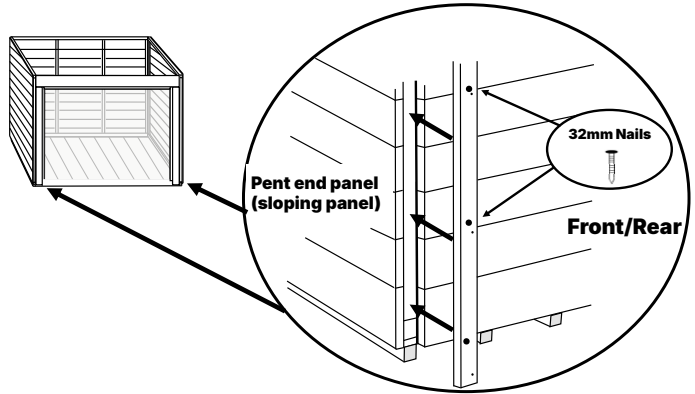

2. Roof

Fix the roof board to the building using 40mm screws directly through the roof sheet into the panel framing.

Once the roof is squared up and screwed down, you can then screw all of the side panels to the floor of the shed using 60mm screws.

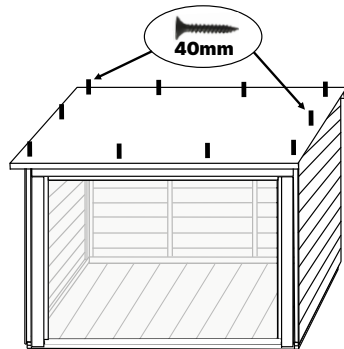

3. Felt

Lay the felt onto the roof ensuring there is a 40mm overhang around the sides and then fix into place the roof using 13mm nails

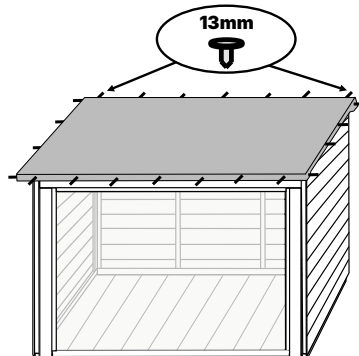

4. Roof trim

Fix the fascias (Barge boards) using 32mm nails.

Ensure to trap the felt between the fascia and the roof board when fixing.

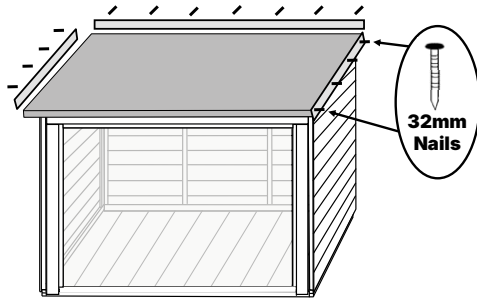

5. Doors

Lie the doors on a flat surface with the cladding facing upwards. Take one T hinge and position on the door as shown below, making sure that the T hinge is directly above the brace on the underside of the door. Fix the T hinge into place with the 25mm black screws. Repeat for the remaining T hinges. With the T hinges secured, position the door squarely in the door frame. Fix the top hinge first with 1 screw and the bottom hinge second with the 25mm black screws. Make sure that the door can open and close freely and then fix the remaining screws into the hinges.

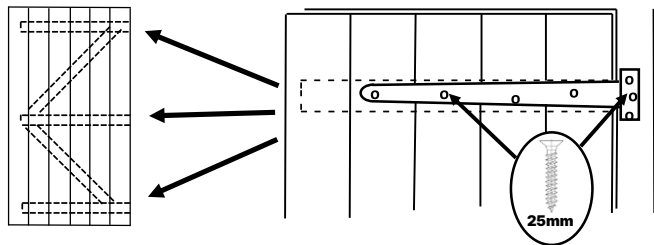

6. Hasp and staple

Attach the hasp and staple to the outside of the doors, using the black 25mm screws, as shown below.

Using a hand saw, you will need to cut out a small section of the weather strip on the door over the middle brace, to allow fitting of the hasp and staple.

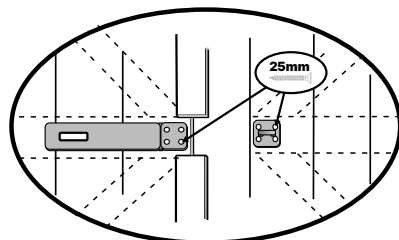



If you have any questions or queries during the assembly of your building please contact us:



Helpline: 01384 897257

Opening hours: Monday – Friday 9am – 4.30pm



Scan the QR code above or visit

www.empiresheds.co.uk