

19 3x2 Apex Garden Tidy

Instruction Manual

3ft x 2ft Apex



Visual representation of your shed, sizes may differ

19 Instruction Manual

The type and quantity of components may vary for different style sheds. Assembly of all shed styles is by the same method as detailed.

Before assembling the shed, please check that all parts are present. Report any shortages or other issues immediately.

No.	Components	Number
1	Front panel	1
2	Rear panel	1
3	Left side panel	1
4	Right side panel	1
5	Door	1
6	Floor	1
7	Roof panel	1
8	Felt	1
9	Tee Hinges	3
10	Roof trim (Barge boards)	4
11	Floor bearers tanalised 25mm x 38mm	5
12	Turn Button	1
13	Hasp and Staple	1
14	Corner cover strips	4
15	Shelf	1

Base.

Ensure the base is level and is built on firm ground, to prevent distortion. The base should be slightly smaller than the external measurement of the building to allow water to run away freely. i.e. the cladding should overlap the base, the building must not be allowed to sit in pooled water during wet conditions. When constructing your base, remember not to build it too close to walls, fences, trees or overhanging bushes as this may cause issues with water ingress over a long period. Always ensure that there will be access to all sides for maintenance work and annual treatment

Timber Information.

Because wood is a natural material, it can alter in appearance due to a variety of factors, such as movement, warping, and splitting, especially in harsh weather. The timber may occasionally have splits, knots, or other visible flaws.

Despite our best efforts to hand-pick wood without splits or knotholes, there may be times when wood is chosen in good faith but has what looks to be a solid knot in it. It's possible that over time or during product movement, these tiny knot holes become loose from the wood, creating a little knot or crack. Regretfully, we cannot be accountable for the product's maturation and can only provide our best recommendations for handling this scenario, should it arise. If the damage is severe, we would suggest replacing the board. Otherwise, we would suggest applying wood filler to the affected area.

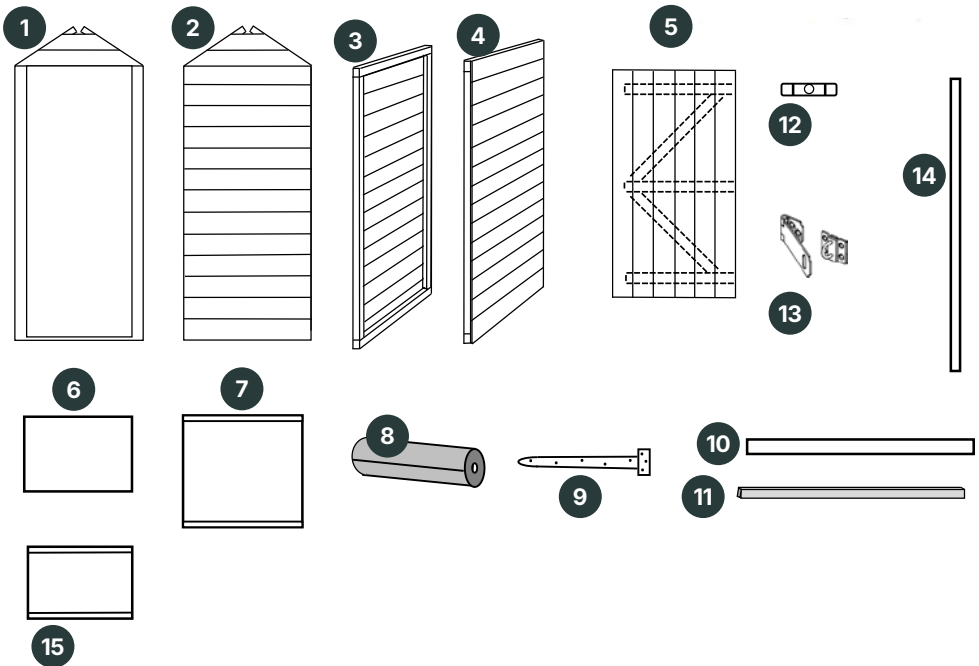

Fixings

60mm screws

32mm ringshank nails

40mm screws

13mm clout nails

25mm black screws

If you have any questions or queries during the assembly of your building please contact us:



Helpline: 01384 897257

Opening hours: Monday – Friday 9am – 4.30pm

We are constantly improving and updating the quality of our products and as such some components may differ from those shown. We reserve the right to change the specification of our products without prior notice.

1. Floor Section

The **floor and floor bearers** are supplied separately.
The **roof** is supplied with batons already attached.

Place each floor bearer approx. 30cms apart. Lay the floor board on top of bearers and nail through the floor into the bearers, ensuring that one bearer is fixed along both outer edges of the floor. Fix the floor bearers to the floor using the 32mm nails spaced every 30cm.

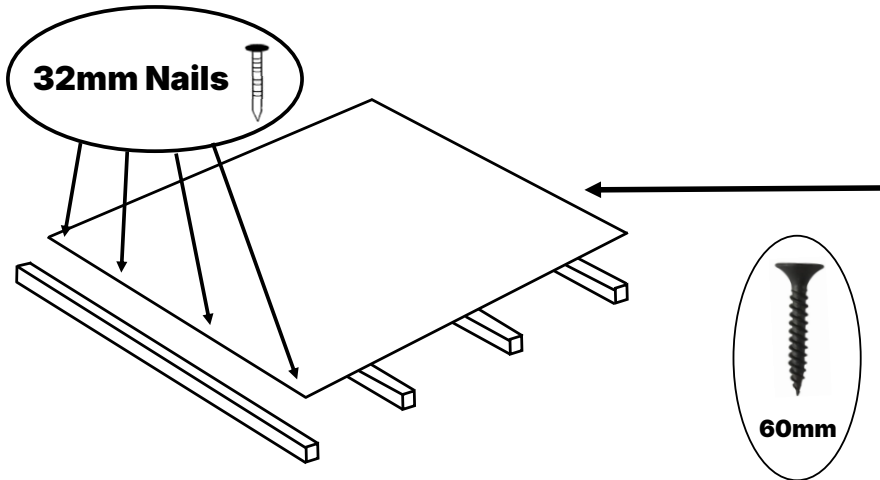

2. Wall Panels

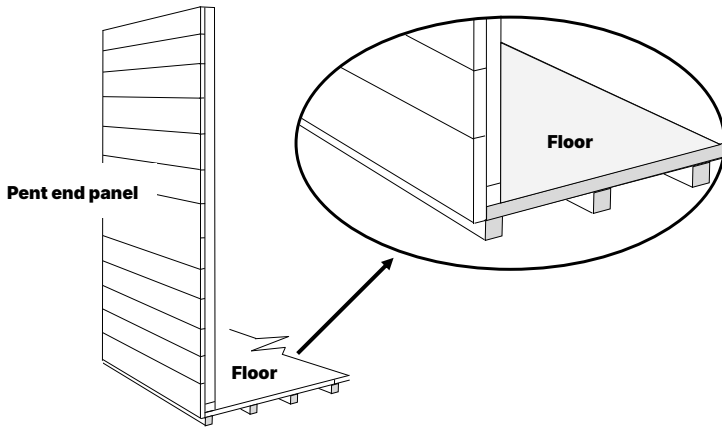

Step 1.

Position the first side panel (one of the panels with the sloping top) so that the edge of the panel is flush with the edge of the floor at both ends and the overhang on the bottom of the panel is butted up to the floor. These panels are the same width as the floor board.

Step 2.

Position the corresponding front or rear panel next to the end panel to make a corner. The cladding of the front/rear panel should be proud of the end panel to allow fitting of the corner cover strips, as shown below.

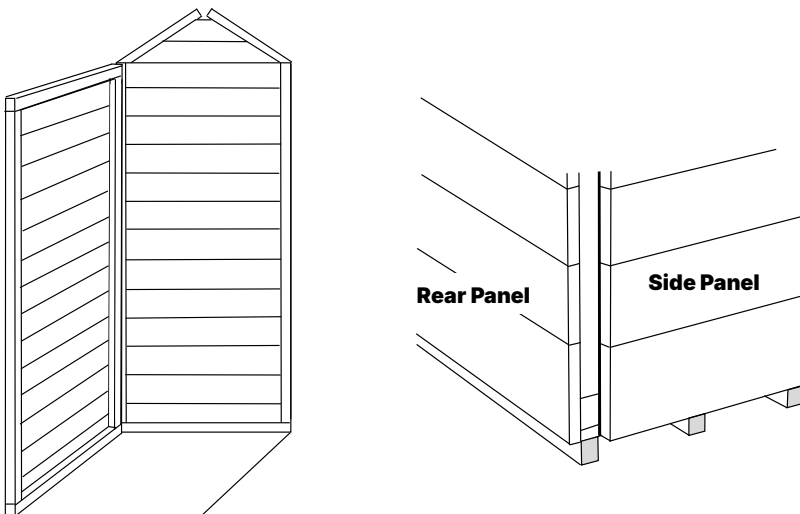

Step 3.

Fix the remaining panels in place using the method shown in step 2.

Do not screw any of the panels to the floor at this point.

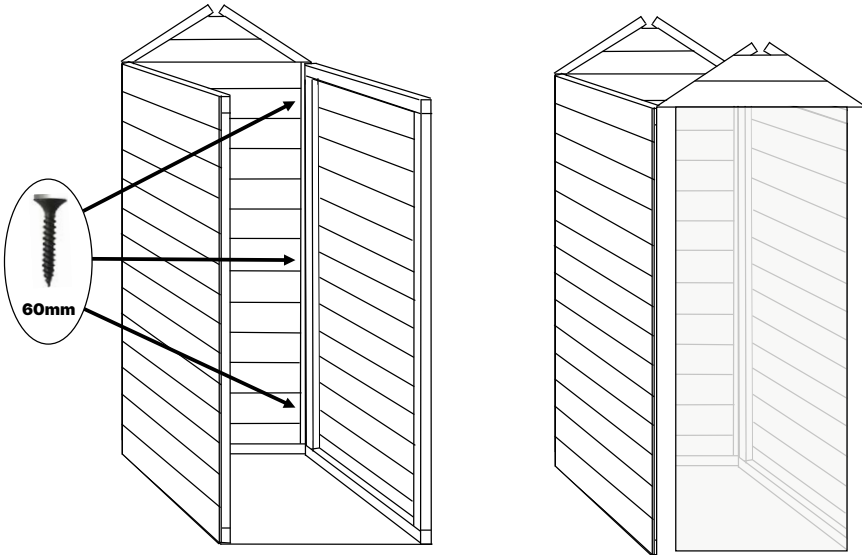
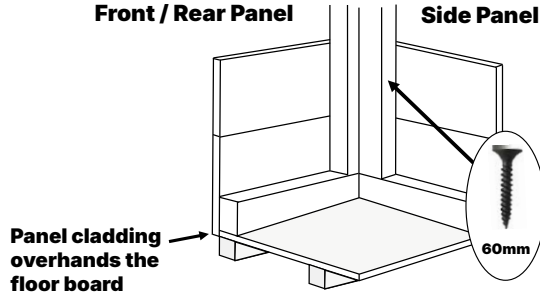

Once all walls are assembled, ensure the shed is now square on the floor. Using the 60mm screws, fix the walls panels to the floor. Do this by screwing through the framing of the wall panel, through the floor and into the floor bearer. Use 2 to 4 screws per wall panel.

Step 4.

Attach the corner cover trim as shown using 32mm nails.

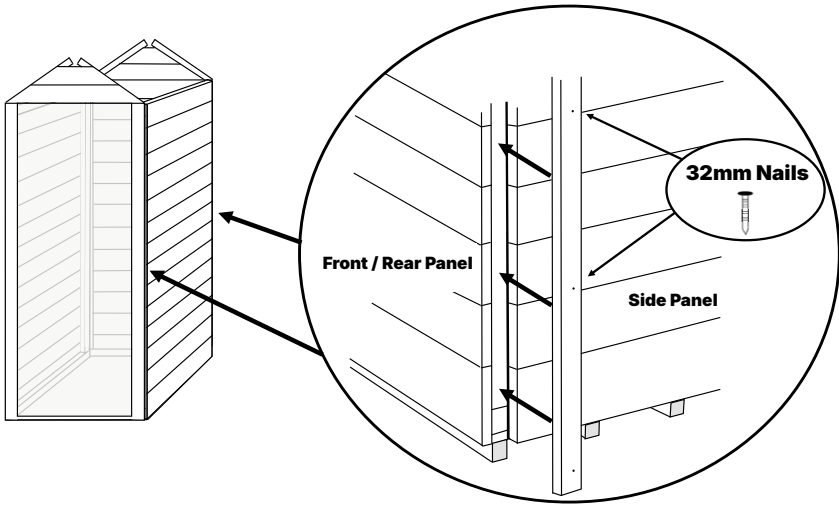

3. Roof

Step 1.

Position the roof boards onto the top of the shed and screw down with 40mm screws.

Once the roof is squared up and screwed down, you can then screw all of the side panels to the floor of the shed using 60mm screws.

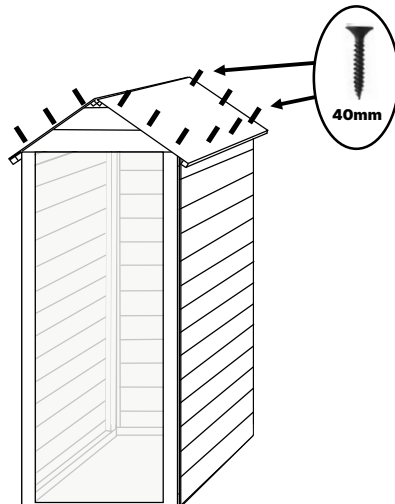

4. Felt

Step 1.

Lay the felt onto the roof ensuring there is a 40mm overhang around the sides. Fold the felt over the edge of the roof and secure using the 13mm felt tacks all around the edges.

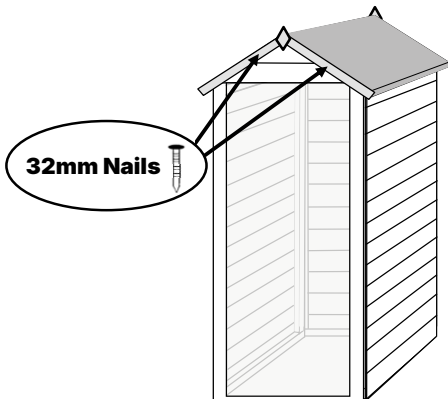
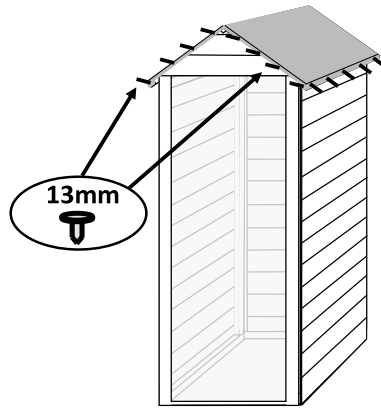

Step 2.

Firstly, fix the fascias to the edges of the front and rear of the roof using 32mm nails, you may need to trim these to size.

Ensure to trap the felt between the fascia and the roof board when you are nailing them.

Once you have fixed these in place, attach the diamond finials using 2 × 32mm nails in each.

Step 3.

Position the shelf at the desired height and fix into position by screwing into the shelf framing from the outside of the shed using 60mm screws.

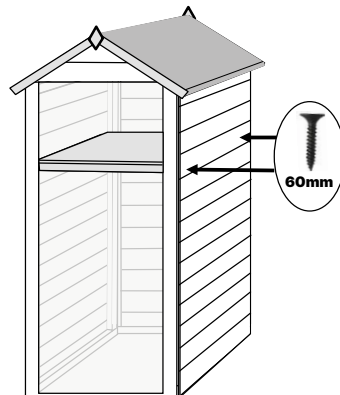

5. Doors

Lie the door on a flat surface with the cladding facing upwards. Take one T hinge and position on the door as shown below, making sure that the T hinge is directly above the brace on the underside of the door. Fix the T hinge into place with the 25mm black screws. Repeat for the remaining T hinges. With the T hinges secured, position the door squarely in the door frame. Fix the top hinge first with 1 screw and the bottom hinge second with the 25mm black screws. Make sure that the door can open and close freely and then fix the remaining screws into the hinges.

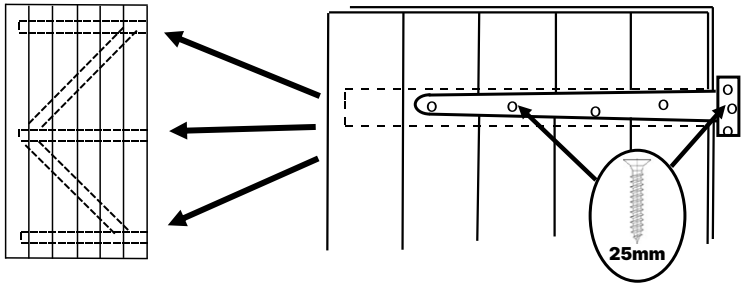

6. Hasp and Staple

Attach the hasp and staple to the outside of the door and door frame, using the black 25mm screws, as shown below.

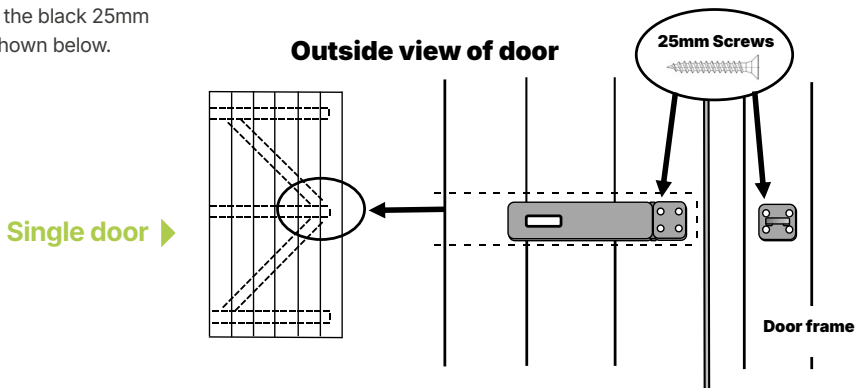



If you have any questions or queries during the assembly of your building please contact us:



Helpline: 01384 897257

Opening hours: Monday – Friday 9am – 4.30pm



Scan the QR code above or visit

www.empiresheds.co.uk