

16 Large Pent Potting Sheds

Instruction Manual

8ft wide

8ft to 20ft deep



Visual representation of your shed, sizes may differ

16 Instruction Manual

Please follow the instructions for safe unpacking of your garden building

Base.

Ensure the base is level and is built on firm ground, to prevent distortion. The base should be slightly smaller than the external measurement of the building to allow water to run away freely, i.e. the cladding should overlap the base. When constructing your base, remember not to build it too close to walls, fences, trees or overhanging bushes as this may cause issues with water ingress over a long period.

Timber Information.

As timber is a natural product it is prone to changes in appearance during different weather conditions, including swelling, warping and splitting. Whilst every effort is made to hand pick timber to avoid splits and knot holes, there may be instances where the timber has shrunk and small knots may have fallen out, or a small split may have appeared.

Unfortunately, we can not take responsibility for the seasoning of the timber, but we can give helpful advice on how to treat the issue. None of the mentioned instances will affect the structural integrity of the product.

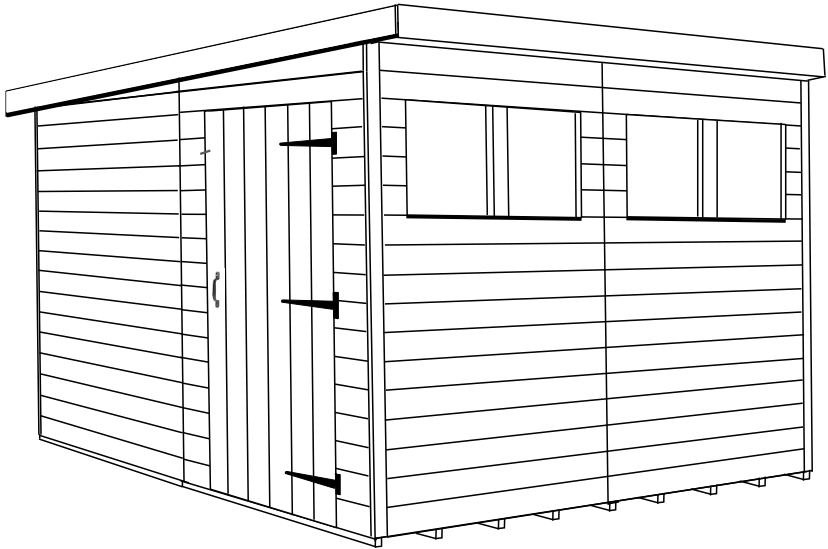
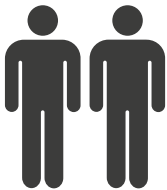

Image for illustration purposes only, your shed may vary



Warning

Please follow the instructions for safe unpacking of your garden building







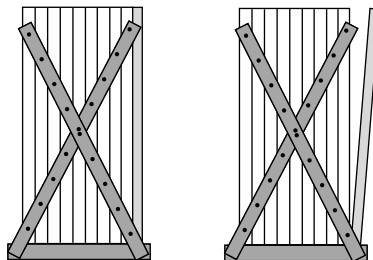









Two people required

- Please read through the instructions before attempting to build the product.
- Position the pallet on firm level ground
- Cut the plastic banding
- Unpack the pallet by removing the screws from one panel at a time as shown.
- Empire Sheds cannot take responsibility for your safety while handling this product.



16 Parts Checklist

		8×8	10×8	12×8	14×8	16×8	18×8	20×8
4×4ft Floor		4	4	6	6	8	8	10
2×4ft Floor		0	2	0	2	0	2	0
4ft Plain Panel		3	3	4	4	5	5	6
4ft Door Panel		1	1	1	1	1	1	1
4ft Window Panel		4	4	5	5	6	6	7
2ft Window Panel		0	1	0	1	0	1	0
2ft Plain Panel		0	1	0	1	0	1	0
4×6ft Pent Roof Panel		2	2	3	3	4	4	5
2×6ft Pent Roof Panel		0	1	0	1	0	1	0
4×2ft Pent Roof Panel		2	2	3	3	4	4	5
2×2ft Pent Roof Panel		0	1	0	1	0	1	0
2×4ft Potting Shed Shelf		4	2	6	4	8	6	10
2×6ft Potting Shed Shelf		0	2	0	2	0	2	0
Potting Shed Shelf Upright		4	4	6	6	8	8	10

		8×8	10×8	12×8	14×8	16×8	18×8	20×8
4ft Heavy Duty Bearer (1190×56mm)		4	4	4	4	4	4	5
4ft Top Panel		2	2	3	3	4	4	4
2ft Top Panel		0	1	0	1	0	1	0
Roof Joining Batons (28×42mm)		4	6	7	9	10	12	13
70mm Bargeboard 6ft		0	4	8	4	0	12	8
70mm Bargeboard 4ft		12	8	4	12	20	4	12
58mm Cover Strips		8	10	10	12	12	14	14
Felt		3 pcs	3 pcs	3 pcs	3 pcs	3 pcs	3 pcs	3 pcs
Fixing Pack		2	2	2	2	2	2	2
4ft Pent Gable Top (Front and Back for Left and Right)		2 pairs	2 pairs	2 pairs	2 pairs	2 pairs	2 pairs	2 pairs
300mm Floor Joining Batons		4	6	6	8	8	10	10

1. Floor Section

The **floor and floor bearers** are supplied separately.
The **roof** is supplied with batons already attached.

Step 1.

Your shed floor will be made up of various 4ft x 4ft boards and for certain sizes 4ft x 2ft boards. These need to be laid out onto your firm level base as detailed in the example images, with the cut boards on the outer edge of the floor

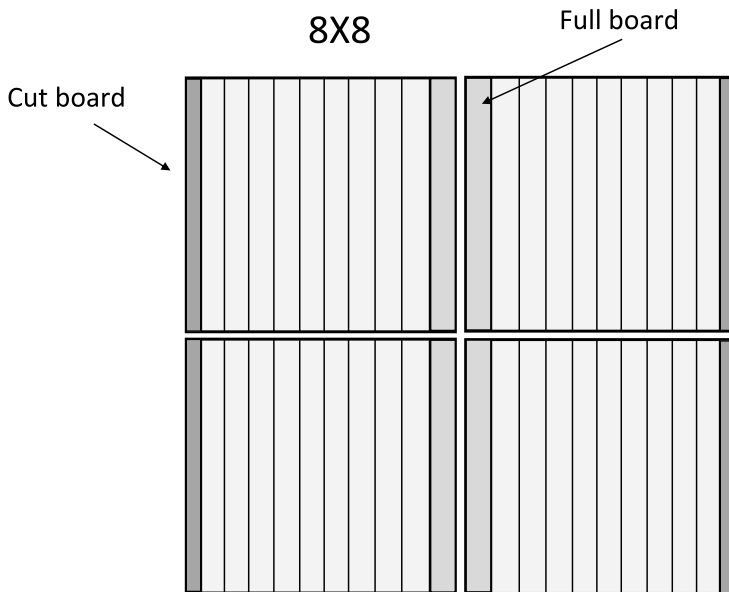

Step 2.

Once you have the floor panels in position, you now need to join them together.

Turn the floor panels over and join them together using 2 joining blocks for each row of panels, as shown below.

Once you have 4 panels joined together turn them over and repeat the process for the remaining panels. (Don't join more than 4 panels together at once, as they will become too difficult to turn over.)

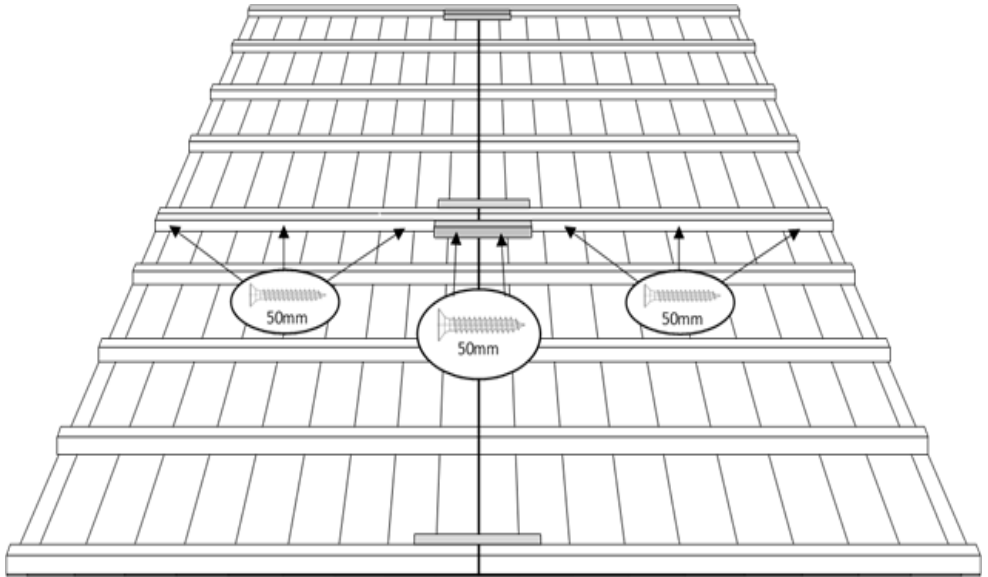

Step 3.

Once the panels are all turned back over, you will need to screw the larger sections together using 70mm screws

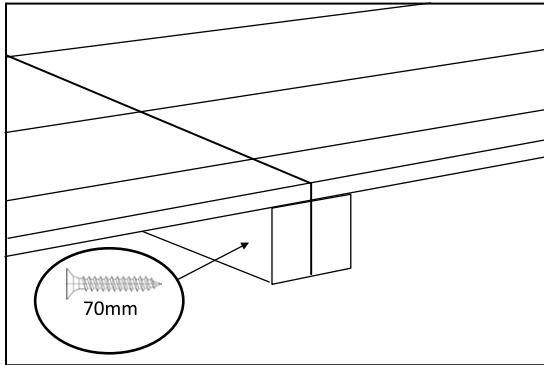

Step 4.

Once the floor panels are all screwed together it is time to attach the heavy duty floor bearers (2 pieces of framing screwed together) to each 8ft end, where the triangular gable tops will fit. The bearers will be 2×4ft lengths for each end. Use 3× 70mm screws for each bearer.

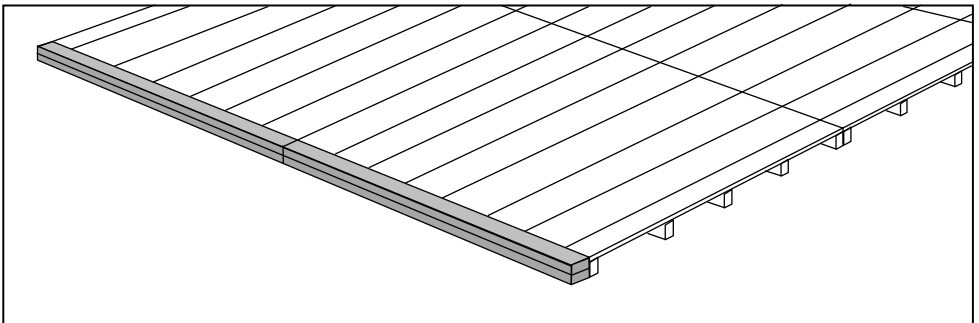

2. Door

Step 1.

Lie the door or doors into the door frame on a flat surface with the cladding facing upwards. Take one T hinge and position on the door as shown below, making sure that the T hinge is directly above the brace on the underside of the door. Fix the T hinge into place with the 25mm screws. Repeat for the remaining T hinges. With the T hinges secured, position the door squarely in the door frame. Fix the top hinge first with 1 screw and the bottom hinge second with the 25mm screws. Make sure that the door can open and close freely and then fix the remaining screws into the hinges.

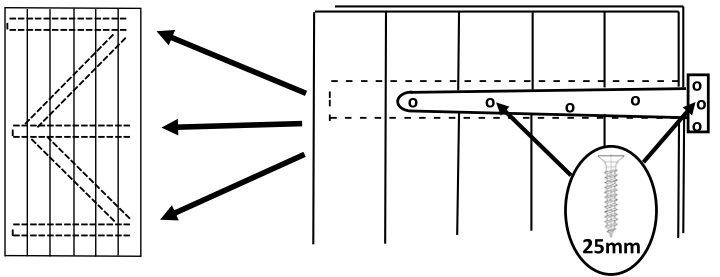
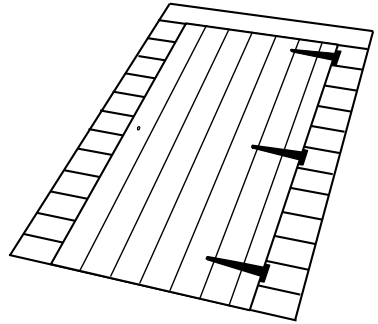

Step 3.

Fix the turn button in place close to the top of the door. Don't screw in too tightly or it won't turn.

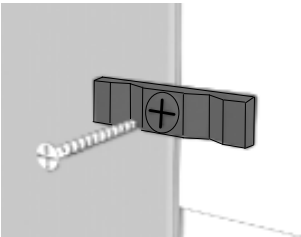

Step 4.

On the inside of the door, line up the lock with the pre-drilled hole in the door and fix in place with the screws.

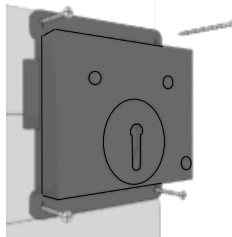

3. Wall Panels

Step 1.

Remove any transport blocks from the bottom of the panels which may be present. Next, lay the wall panels around the shed in the desired positions before assembling. Starting with one gable end of the shed, position one of the 4ft panels on top of the double bearer and ensure that it is flush with the side of the shed.

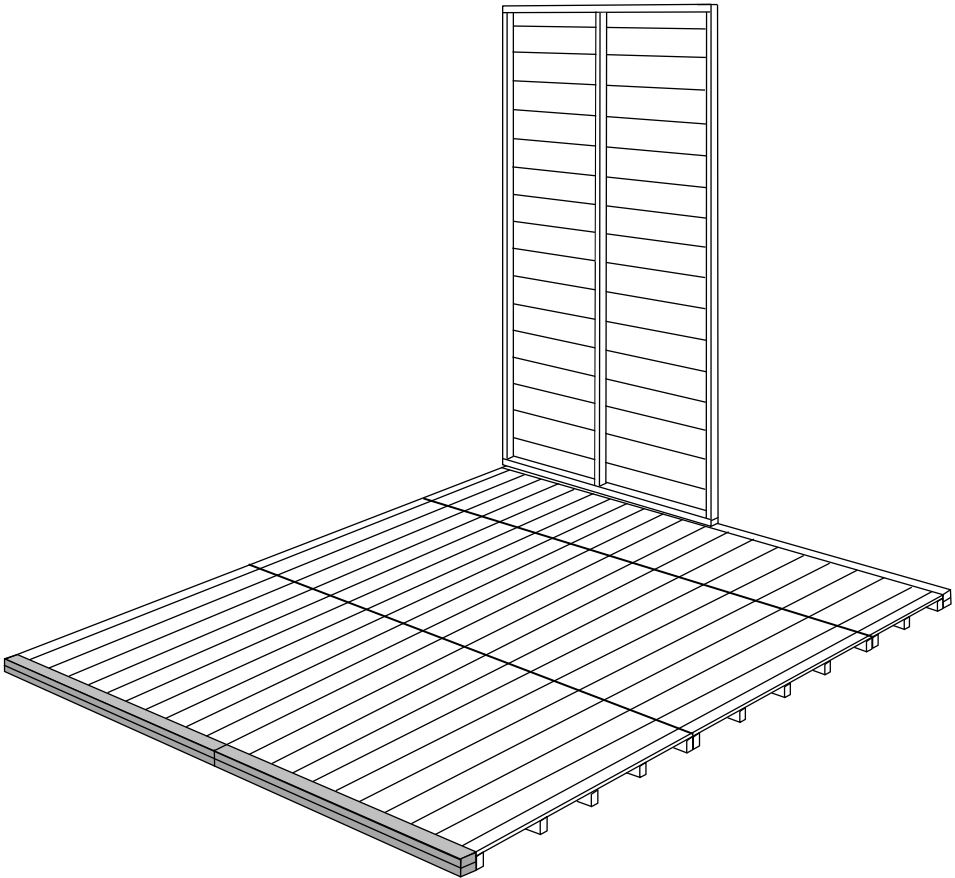

Step 2.

Position another panel to make up the corner. Butt the panel up to the first one and make sure that the tops of the panel are level before securing using 3 × 50mm screws along the join. The ends of the cladding on the side that is being attached, must be proud of the gable end panel, to allow fitting of the corner cover strips later, as shown below

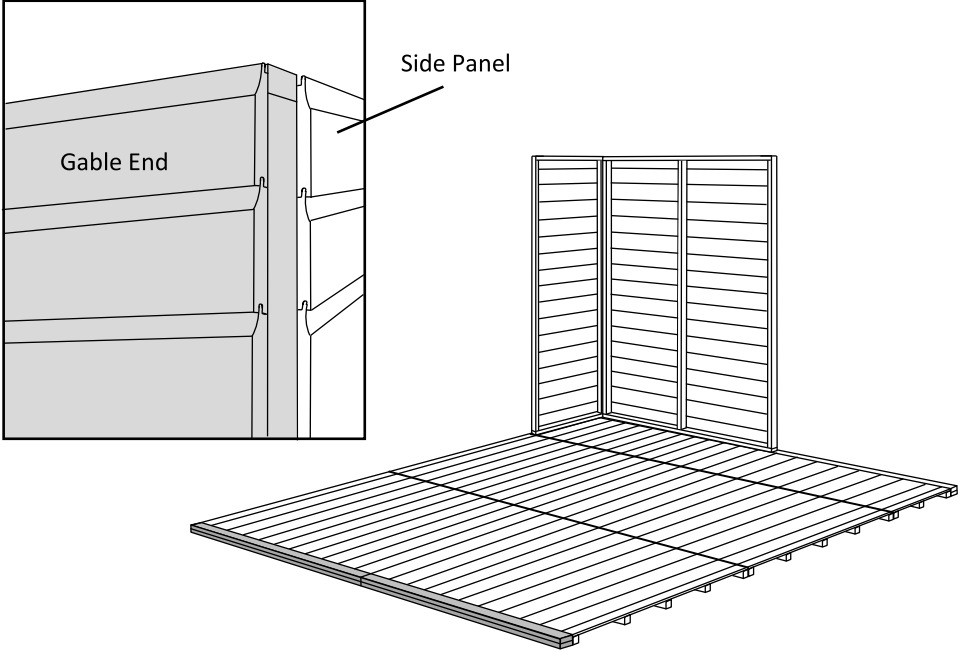

Step 3.

Continue adding panels to the shed in the same way until all of the wall panels are in place.

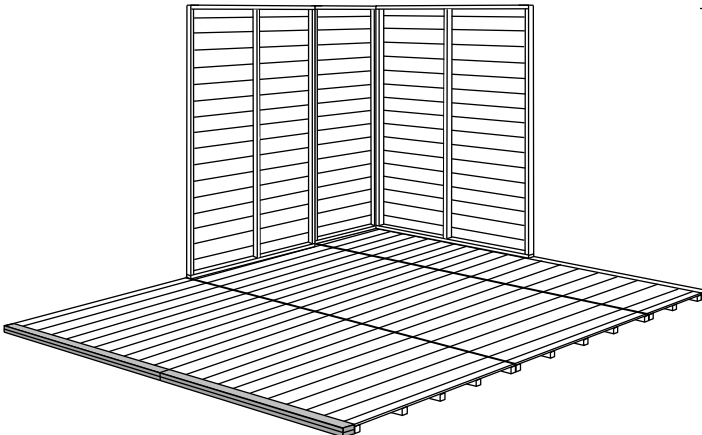

Step 4.

After you have attached all of the wall panels together, you must fasten them to the floor with the accompanying 70mm screws. Screw 2 x screws into the floor for each wall panel (internally), making that the screws go through the framing at the bottom of the side/gable walls, the floor boards, and into the floor joists.

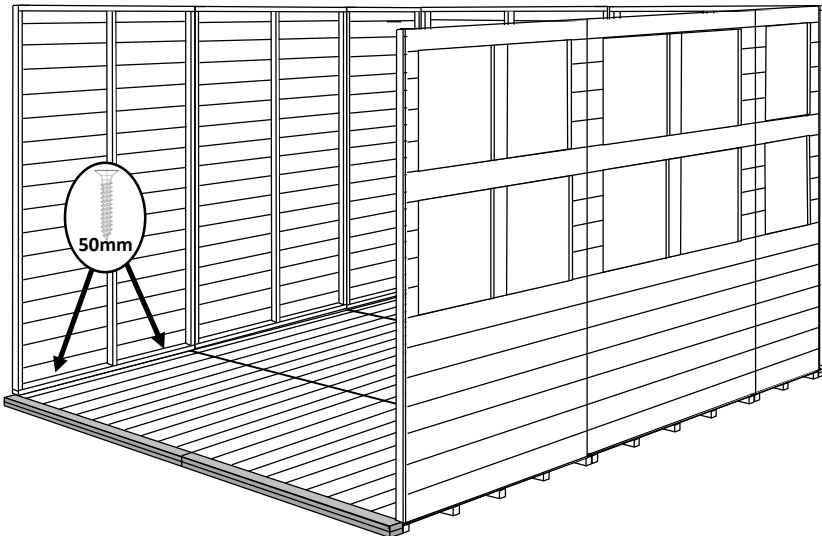
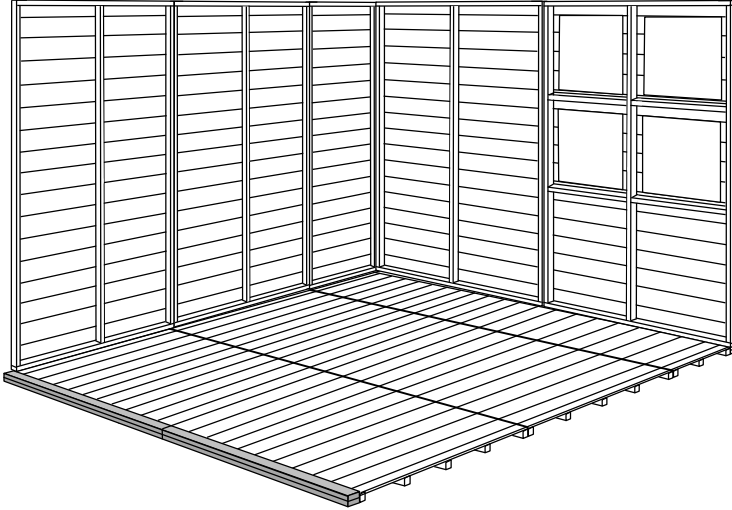

4. Front and Top Gables

Step 1.

Choose which side of the shed you wish to be taller and then fix the pent top panels in place using 50mm screws as shown below.

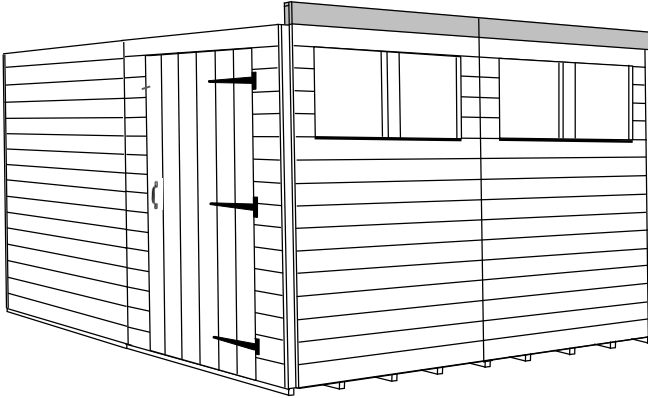

Gable tops
(left and right pair)

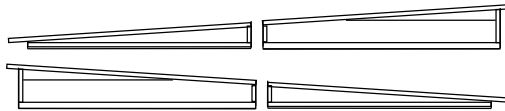

Step 2.

Attach the gable tops to the gable end panels (the panels which are on the heavy-duty bearers) by screwing up through the internal framing using 50mm screws. Make sure that they are flush with the front and back of the panels that they are sitting on.

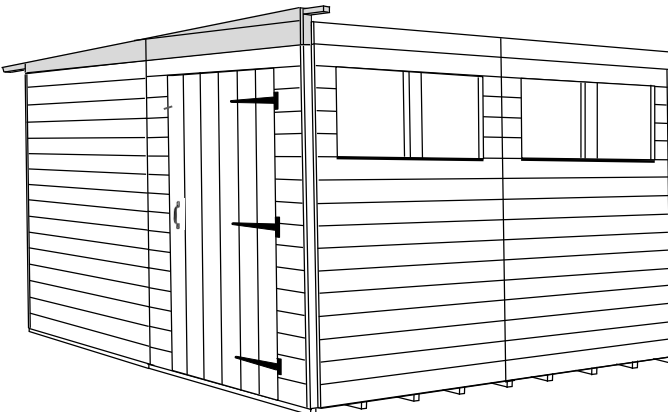

5. Roof

Depending on the size of your building, the size and amount of roof panels will vary as shown in the table below.

	2×6ft Roof	2×2ft Roof	4×6ft Roof	4×2ft roof	Roof joining Batons (28×42mm)
8×8			2	2	4
10×8	1	1	2	2	6
12×8			3	3	7
14×8	1	1	3	3	9
16×8			4	4	10
18×8	1	1	4	4	12
20×8			5	5	13

Each 8ft roof section needs to be made by joining together a 6ft panel and a 2ft panel using the 4ft long roof joining batons provided, and securing with 50mm screws.

The framing on the roof panels needs to run parallel to the gables, from the taller side of the shed down to the lower side of the shed. It is better to alternate the roof panels to alleviate the chance of the roof sagging over time. The following drawings show how the roof fits together. Make one 8ft section at a time and add to the roof one by one, before screwing the sections together.

Example of 12×8ft roof

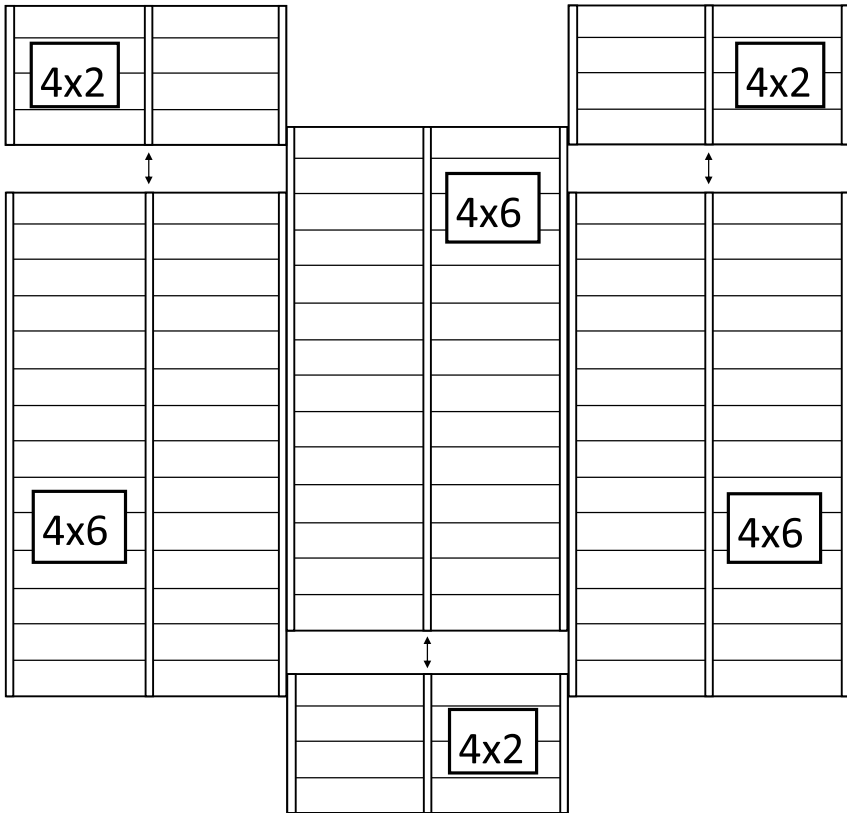

The above drawing shows how all 8ft pent roofs fit together, by alternating the large and small panels. Join the 8ft sections together with the joining batons as shown, before fitting on to the shed.

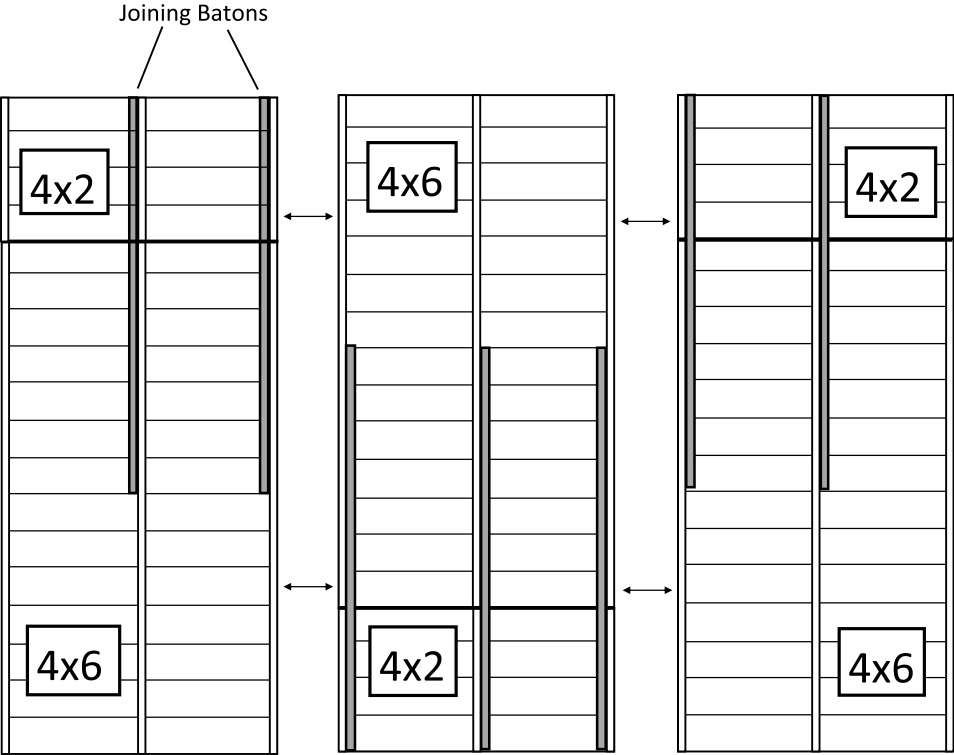

Step 1.

Depending on the size of the building that you have purchased, your roof will consist of 2ft wide or 4ft wide roof panels. Position the roof panels in place so that the framing on the roof panel runs from the high side of the shed to the low side. Make sure that the front and back of the roof panels are flush with the framing on the front and back of the gable tops.

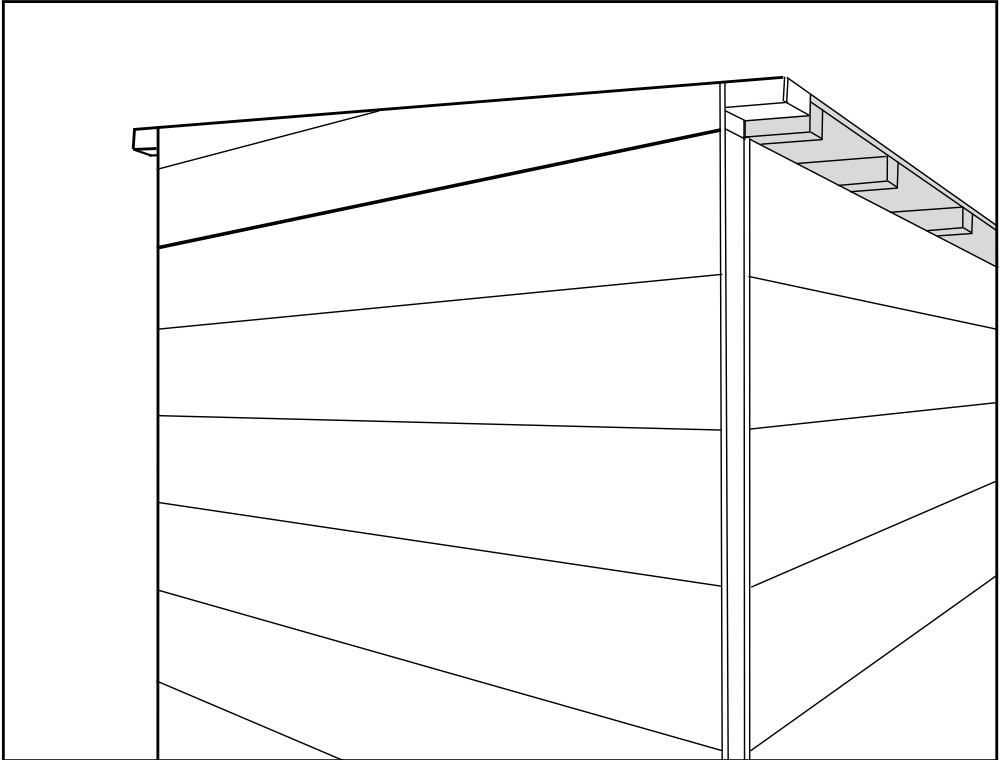

Step 1.

Attach the rear barge boards to the back of the roof and the underside of the roof as shown using the 40mm nails. These fascia boards may come in more than one sections and need cutting down to size with a saw, depending on the size of shed that you have. Make sure that you use the wider strips of wood, as the narrower ones are the corner cover strips, to be attached later.

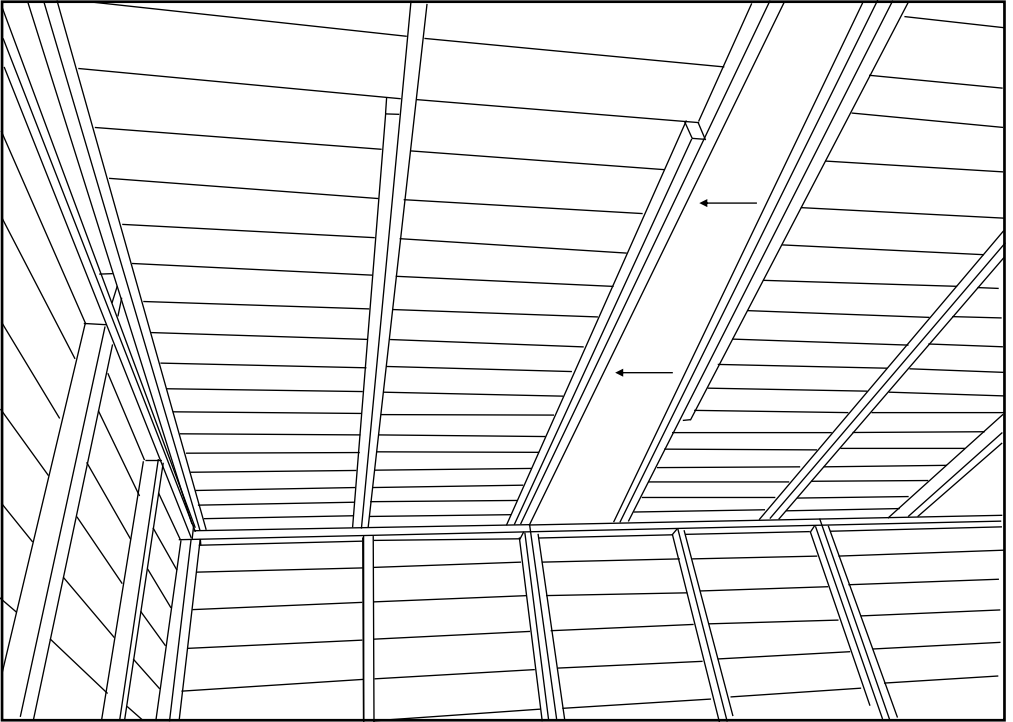

Roof viewed from inside

6. Felt

Step 1.

Attach the rear barge boards to the back of the roof and the underside of the roof as shown using the 40mm nails. These fascia boards may come in more than one sections and need cutting down to size with a saw, depending on the size of shed that you have. Make sure that you use the wider strips of wood, as the narrower ones are the corner cover strips, to be attached later.

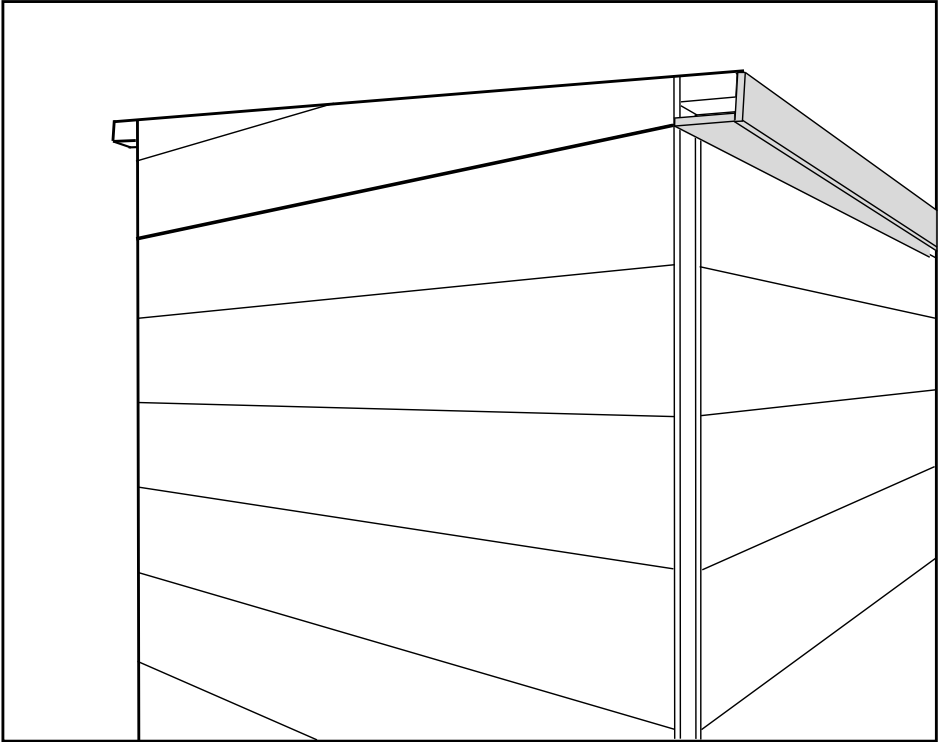

Use step Ladders when nailing the felt on to the roof, **do not climb on top of the roof** as it is not designed to hold the weight of a person.

Step 1

Starting with the lower part of the roof using 13mm nails, attach the felt to the roof ensuring there is a 30mm overhang around the sides. Do not cover the underside roof bargeboard with felt. See below.

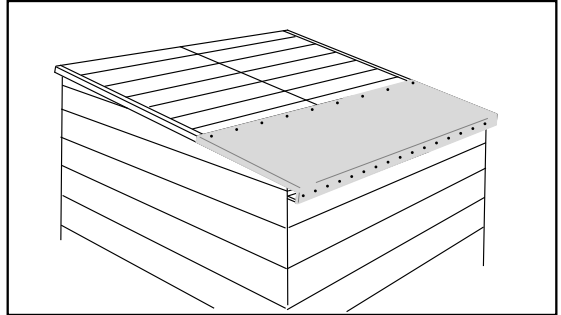

Step 2

Lay the remaining pieces of felt onto the roof as shown, ensuring that each piece overlaps the previous piece by at least 20cm.

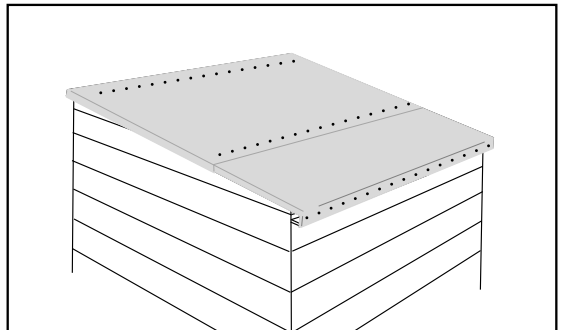

7. Trim

Step 1

Using the 40mm nails attach the barge boards to the front and sides of the roof as shown. You may need to cut down the barge boards to fit, depending on the size of building that you have.

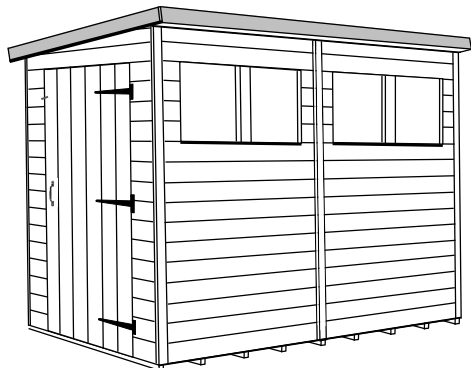

Step 2

Attach the soffit to the underside of the roof in the same way. Again, these will need trimming to size. Note: there will be a gap left between the front panel and the soffit to allow moisture to escape from the shed and prevent damp.

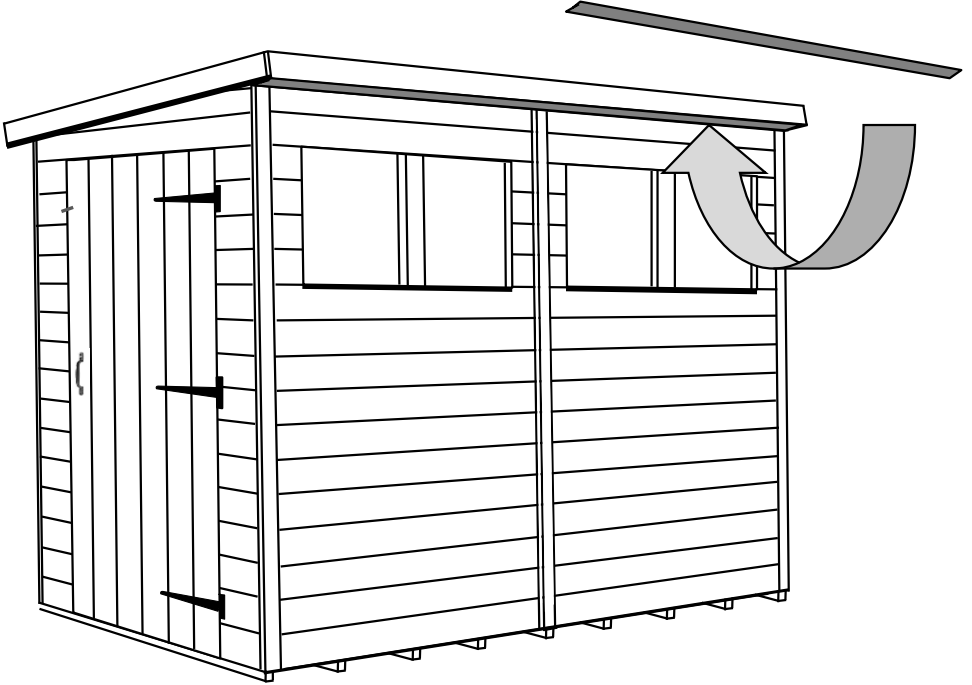

Step 3

Finally, attach the cover trim to all corners and all joins between panels using 4× 40mm nails for each strip, as shown. Again these may need trim-ming to size

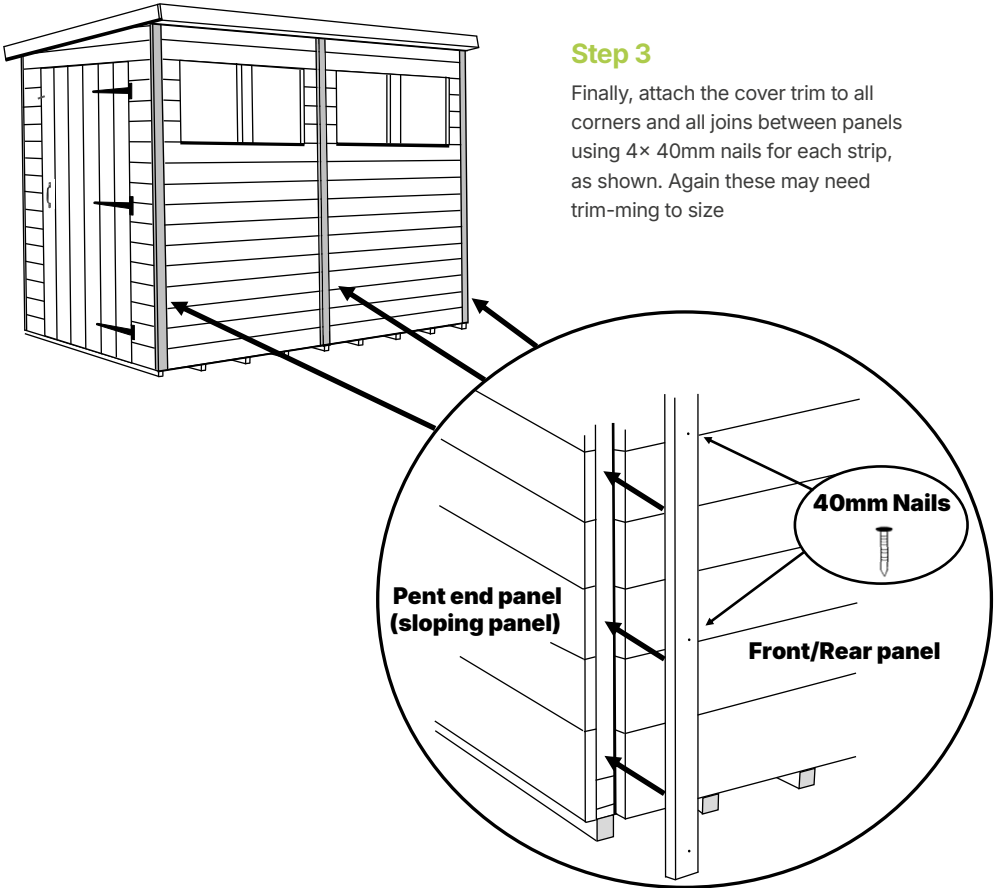

8. Windows

The glazing for the windows is already fitted, but we recommend applying a bead of waterproof sealant (not supplied) around the outside edge of the window to help prevent water ingress. Make sure that you seal the bottom corners at the edge of the window sill.

9. Assembling the staging unit

Please note:

- The staging units may need to be cut down to size depending on where you decide to position them. Make sure that they are correctly sized before erecting them.
- From the fixing pack use the 70mm screws provided to join the shelves to the framing.
- Ensure that when attaching the shelves to the shed side panels you only screw into the framing of the shed.

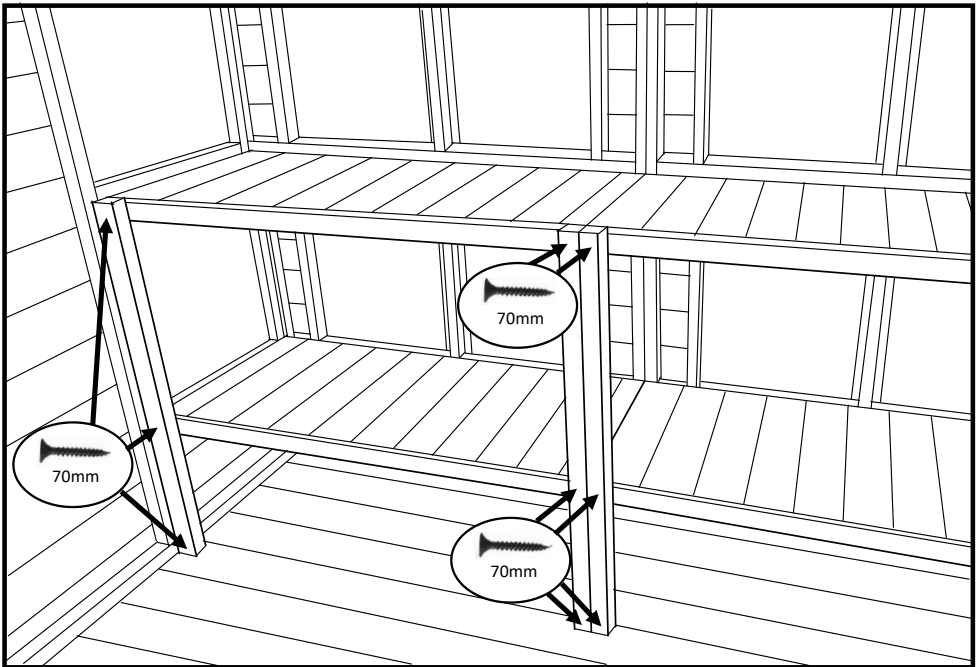

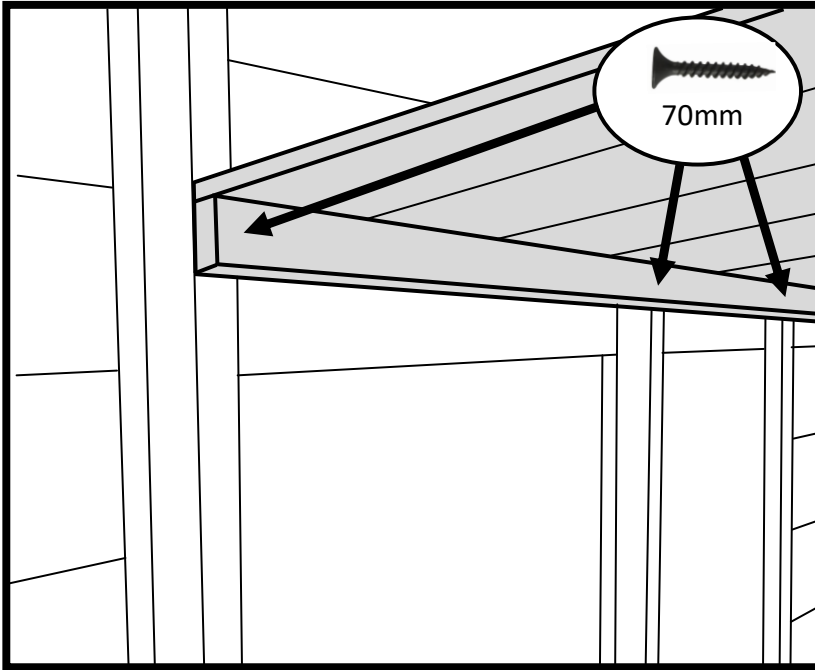

Step 1

Make sure that the shelves are level using a spirit level before screwing them together. It is best to drill a pilot hole to avoid the timber splitting.

Step 2

Once you have all of the shelves in place, screw the legs to the floor of the shed with the 70mm screws.



If you have any questions or queries during the assembly of your building please contact us:



Helpline: 01384 897257

Opening hours: Monday – Friday 9am – 4.30pm



Scan the QR code above or visit

www.empiresheds.co.uk