

05 Small Pressure Treated Pent Garden Shed

Instruction Manual

4ft, 5ft, 6ft, 7ft, 8ft wide

3ft, 4ft, 5ft, 6ft, 7ft deep

All window and door variations



05 Instruction Manual

The type and quantity of components may vary for different style sheds. Assembly of all shed styles is by the same method as detailed.

Before assembling the shed, please check that all parts are present.

Report any shortages or other issues immediately.

No.	Components	Number
1	Front panel	1
2	Rear panel	1
3	Left side panel	1
4	Right side panel	1
5	Felt	1
6	Floor (may be 1 or 2 panels)	1 or 2
7	Roof panel (may be 1 or 2 panels)	1 or 2
8	Door	1 or 2
9	Windows (optional)	Optional
10	Window bead 15mm x 20mm (optional)	Optional
11	Floor bearers tanalised 26mm x 38mm	Variable
12	Barge boards	4
13	Tee Hinges	3 (single door) / 6 (double door)
14	Turn button	1 (single door) / 2 (double door)
15	Corner cover strips 11mm x 41mm	4
16	Hasp and Staple	1

Base.

Ensure the base is level and is built on firm ground, to prevent distortion. The base should be slightly smaller than the external measurement of the building to allow water to run away freely, i.e. the cladding should overlap the base, the building must not be allowed to sit in pooled water during wet conditions. When constructing your base, remember not to build it too close to walls, fences, trees or overhanging bushes as this may cause issues with water ingress over a long period. Always ensure that there will be access to all sides for maintenance work and annual treatment

Timber Information.

Because wood is a natural material, it can alter in appearance due to a variety of factors, such as movement, warping, and splitting, especially in harsh weather. The timber may occasionally have splits, knots, or other visible flaws.

Despite our best efforts to hand-pick wood without splits or knotholes, there may be times when wood is chosen in good faith but has what looks to be a solid knot in it. It's possible that over time or during product movement, these tiny knot holes become loose from the wood, creating a little knot or crack. Regretfully, we cannot be accountable for the product's maturation and can only provide our best recommendations for handling this scenario, should it arise. If the damage is severe, we would suggest replacing the board. Otherwise, we would suggest applying wood filler to the affected area.

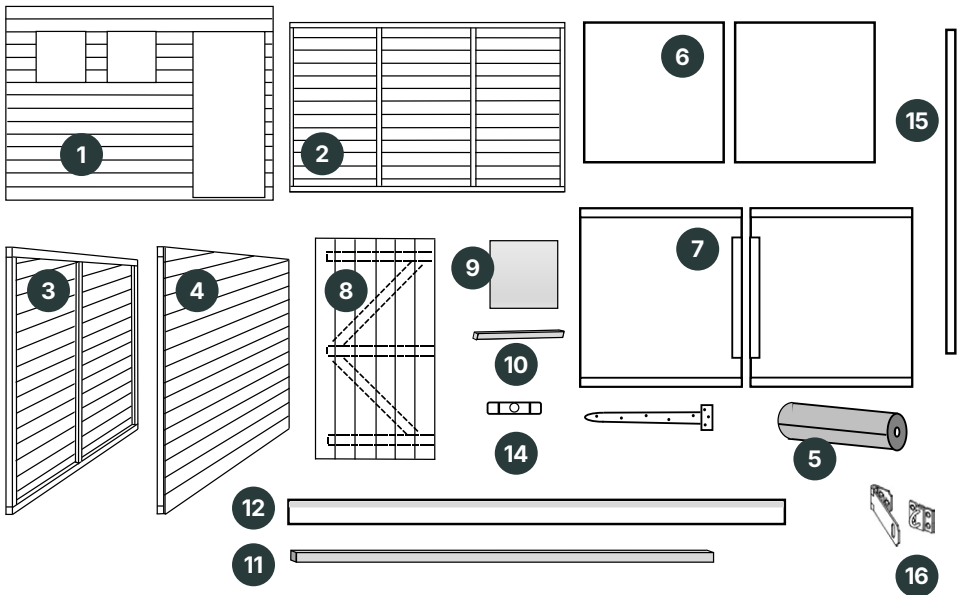

Fixings

60mm screws

40mm screws

25mm black screws

32mm ringshank nails

13mm clout nails

30mm panel pins (windows options only)

If you have any questions or queries during the assembly of your building please contact us:



Helpline: 01384 897257

Opening hours: Monday – Friday 9am – 4.30pm

We are constantly improving and updating the quality of our products and as such some components may differ from those shown. We reserve the right to change the specification of our products without prior notice.

1. Floor Section

The **floor and floor bearers** are supplied separately.
The **roof** is supplied with batons already attached.

If your floor has more than one floor board please go to **section 1b**

Place each floor bearer approx. 30cms apart.
Lay the floor board on top of bearers and nail through the floor into the bearers, ensuring that one bearer is fixed along both outer edges of the floor. Fix the floor bearers to the floor using the 32mm nails spaced every 30cm.

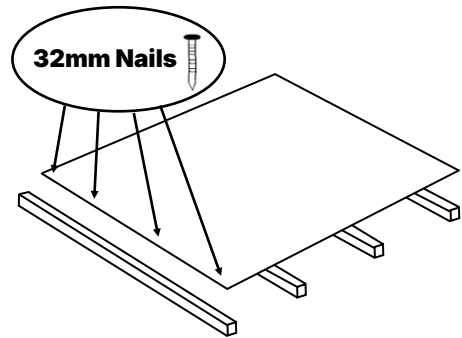

Section 1b

If you floor has more than one board, attach the floor bearers as shown below. Starting at one end, place each floor bearer approx. 30cms apart ensuring that one bearer is fixed along both outer edges of the floor. Where two boards meet, ensure that they are joined together onto one floor bearer as shown below.

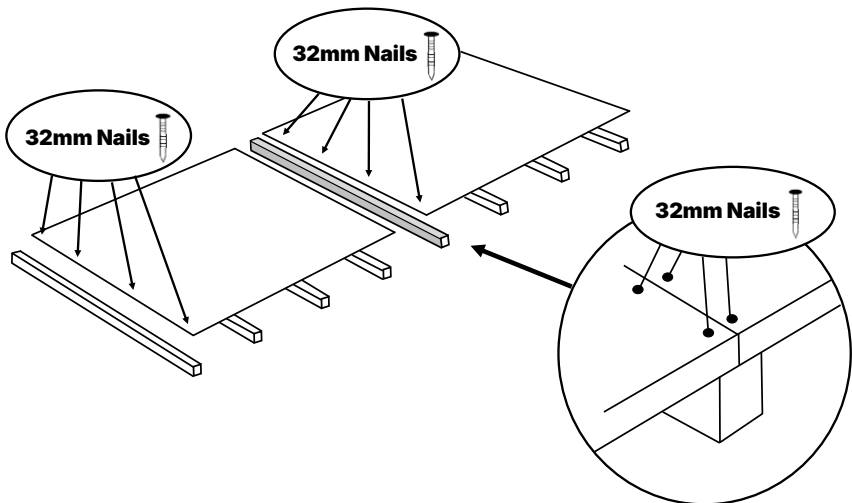

2. Wall Panels

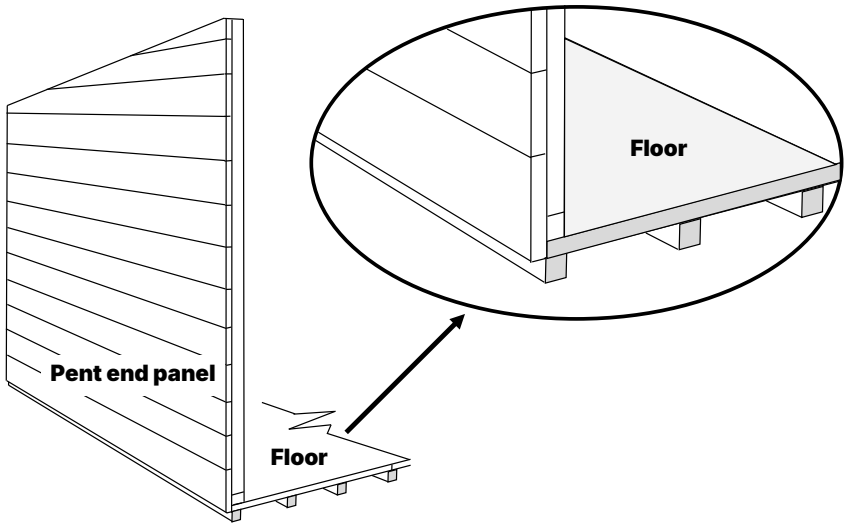

Step 1.

Position the first side panel (one of the panels with the sloping top) so that the edge of the panel is flush with the edge of the floor at both ends and the overhang on the bottom of the panel is butted up to the floor. These panels are the same width as the floor board.

Step 2.

Position the corresponding front or rear panel next to the end panel to make a corner. The cladding of the front/rear panel should be proud of the end panel to allow fitting of the corner cover strips, as shown below.

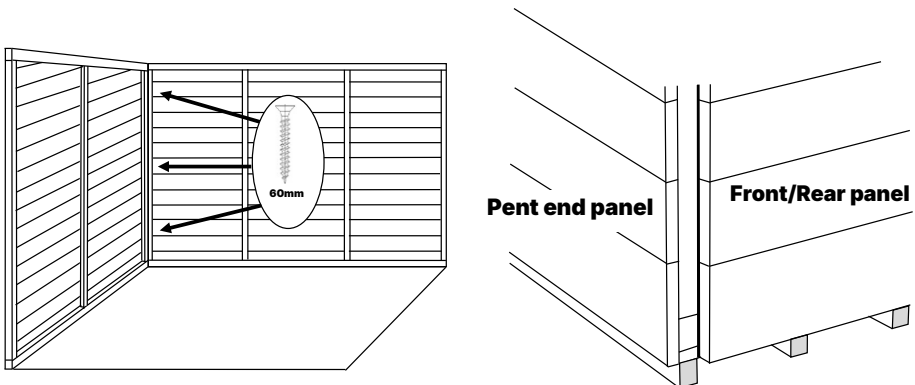

Step 3.

Fix the remaining panels in place using the method shown in step 2.

Do not screw any of the panels to the floor at this point.

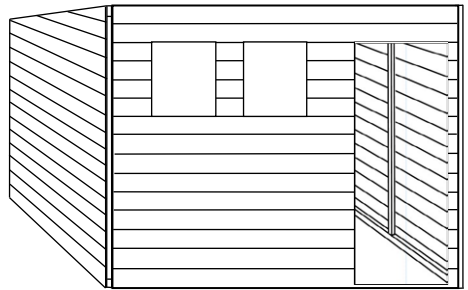
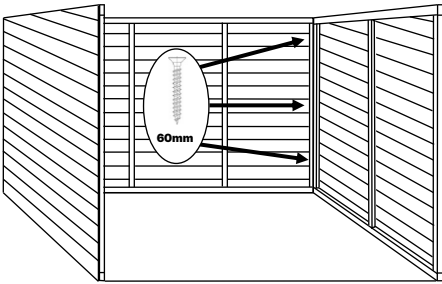
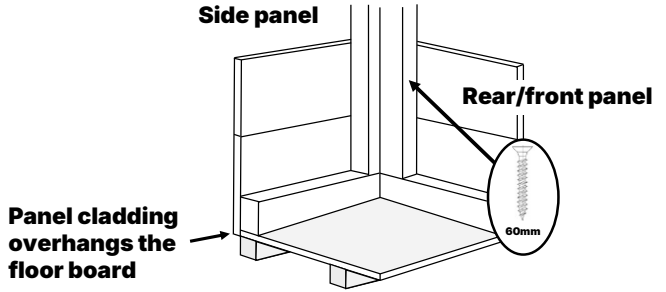

Step 4.

Once all walls are assembled, ensure the shed is now square on the floor. Using the 60mm screws, fix the walls panels to the floor. Do this by screwing through the framing of the wall panel, through the floor and into the floor bearer. Use 2 to 4 screws per wall panel.

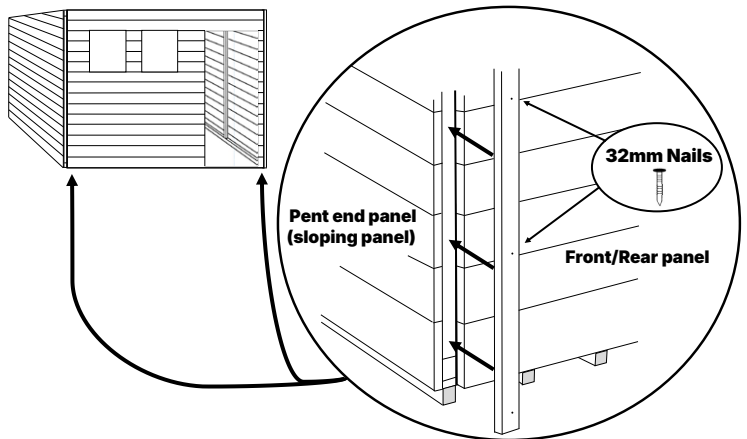

Step 5.

Attach the corner cover trim as shown using 32mm nails.

3. Roof

Step 1.

Position the roof boards onto the top of the shed. The upright batons on the roof boards should run through the middle of the shed and be screwed together as shown.

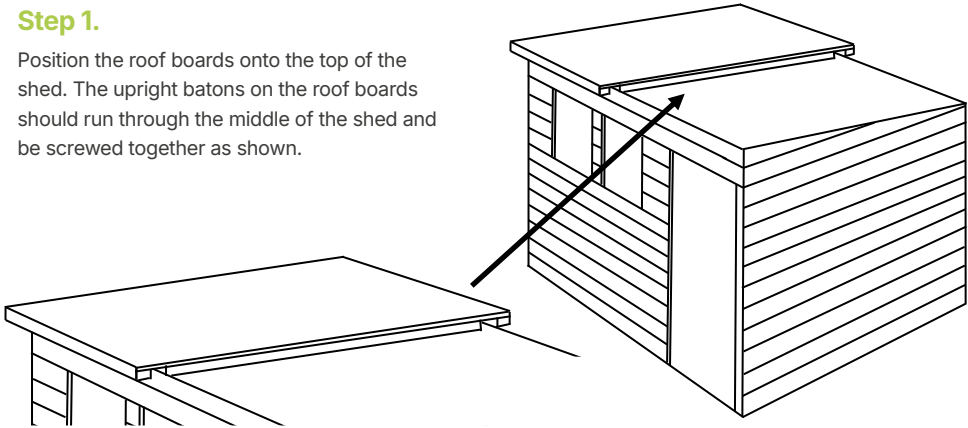

Underside of roof

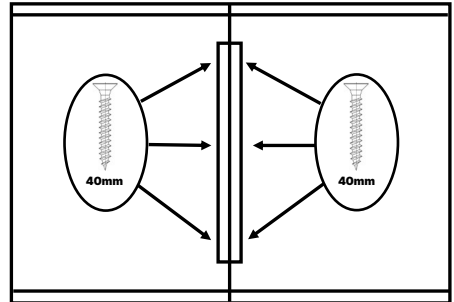
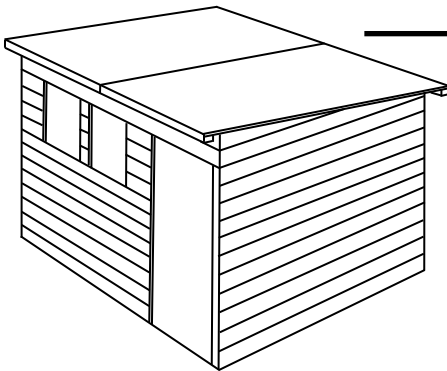

Step 2.

Ensure that the roof panel(s) are squarely positioned on the shed walls, then using the 40mm screws secure the roof by screwing through the roof panel and into the top of the wall panels as shown.

Once the roof is squared up and screwed down, you can then screw all of the side panels to the floor of the shed using 60mm screws.

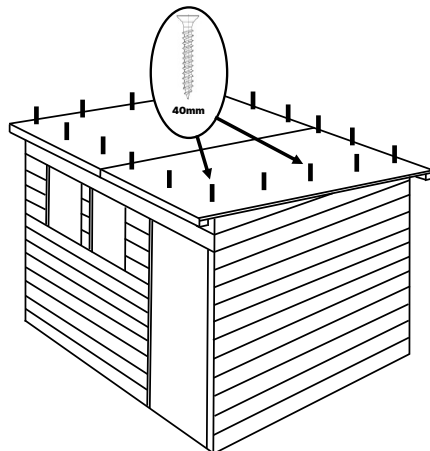

4. Felt

Step 1.

Starting with the lower part of the roof using 13mm nails, attach the felt to the roof ensuring there is a 40mm overhang around the sides.

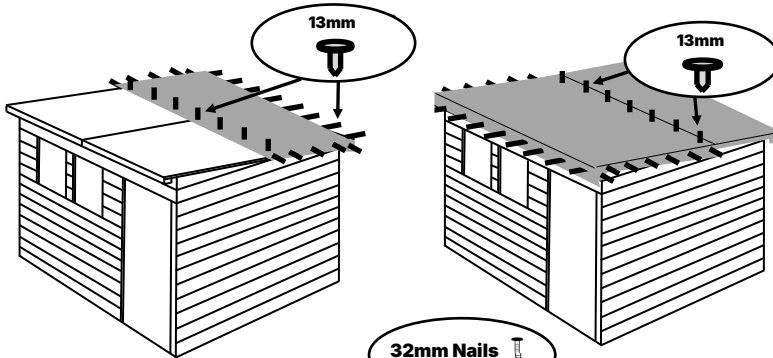

Step 2.

Fix the fascias using 32mm nails. Ensure to trap the felt between the fascia and the roof board.

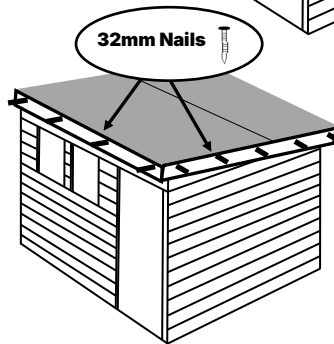

5. Doors

Lay the door on a flat surface with the cladding facing upwards. Take one T hinge and position on the door as shown below, making sure that the T hinge is directly above the brace on the underside of the door. Fix the T hinge into place with the 25mm black screws. Repeat for the remaining T hinges. With the T hinges secured, position the door squarely in the door frame. Fix the top hinge first with 1 screw and the bottom hinge second with the 25mm black screws. Make sure that the door can open and close freely and then fix the remaining screws into the hinges.

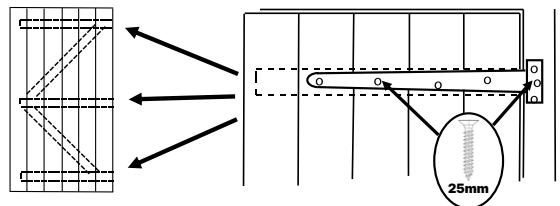

6. Hasp and Staple

Attach the hasp and staple to the outside of the door and door frame, using the black 25mm screws, as shown below.

Single door ▶

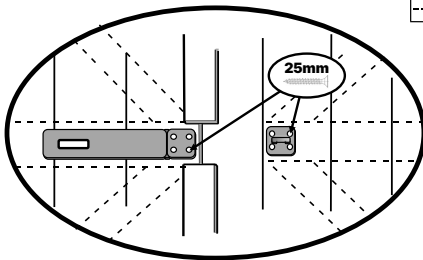

Outside view of door

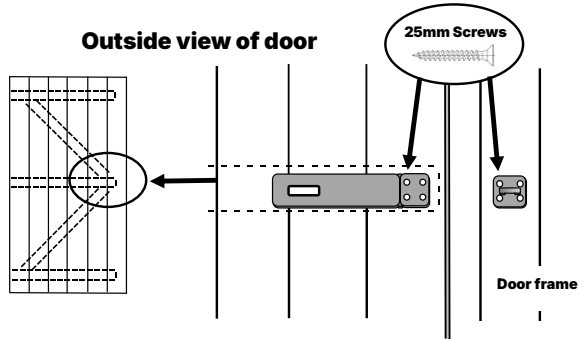

◀ Double door

If your shed has a double door, see opposite. Using a hand saw, you will need to cut out a small section of the weather strip on the door over the middle brace, to allow fitting of the hasp and staple.

7. Windows (optional)

To fit the windows it is recommended that a waterproof sealant is applied around the edge of the glazing before fitting. From the inside of the building fit the styrene window into the frame and secure in place with the 4 strips of window bead. Fix the window bead to the window frame with 30mm panel pins.

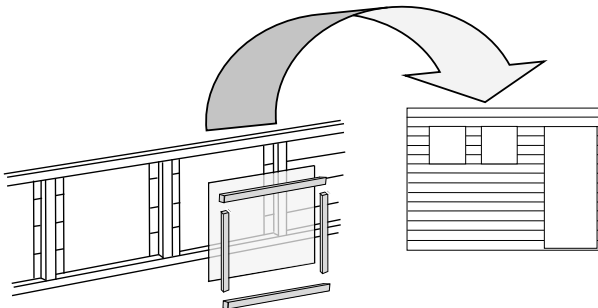

8. Further Treatment

It is generally recommended to allow 30 days before painting or staining pressure treated timber. If the timber is not sufficiently dry, it can cause shrinkage and mould issues in the future.



If you have any questions or queries during the assembly of your building please contact us:



Helpline: 01384 897257

Opening hours: Monday – Friday 9am – 4.30pm



Scan the QR code above or visit

www.empiresheds.co.uk